

Design of High Voltage DC Power Supply Multi-stage for Laboratory Application

Bounthanh Banthasit

Department of Electrical Engineering, Faculty of Engineering at Champasack University, Lao.

Email: th2917@hotmail.com

ບົດຄັດຫຍໍ້

ບົດວິໄຈນີ້ແມ່ນການນຳສະເໜີວິທີການອອກແບບ ເຄື່ອງກຳເນີດໄຟຟ້າແຮງສູງໃນແບບໃໝ່ ທີ່ມີ ແຮງດັນໄຟຟ້າຫຼາຍຂັ້ນ ຫຼື ຫຼາຍລະດັບ ແລະ ສອງຂົ້ວເພື່ອໃຊ້ງານ. ໃນແຕ່ລະຂັ້ນ ແລະ ແຕ່ລະຂົ້ວຂອງ ແຮງດັນແມ່ນສາມາດມາດນຳເອົາໄປໃຊ້ງານໄດ້ໃນຫຼາຍໆຈຸດປະສົງ ຕາມຄວາມເໝາະສົມຂອງການໃຊ້ງານ ສຳລັບຫ້ອງທົດລອງໄຟຟ້າແຮງສູງ. ຫຼັກການດຳເນີນງານໃນການປະຕິບັດທຸກຢ່າງ ພ້ອມທັງການອອກແບບ ແມ່ນອີງໃສ່ເຕັກນິກການປະຕິບັດ ແລະ ອອກແບບຂອງໄຟຟ້າແຮງສູງ ເຊິ່ງໄດ້ນຳເອົາມາພິຈາລະນາ ແລະ ວິເຄາະ. ໃນຂັ້ນຕອນສຸດທ້າຍເຄື່ອງກຳເນີດໄຟຟ້າແຮງສູງທີ່ອອກແບບໄດ້ແມ່ນໄດ້ນຳມາປະດິດສ້າງເພື່ອທົດ ສອບ ທັງນີ້ເພື່ອພິສູດຂອງວິທີການດັ່ງກ່າວ. ຜົນທີ່ໄດ້ຮັບຄື ອຸປະກອນດັ່ງກ່າວແມ່ນສາມາດຈ່າຍກະແສໃຫ້ ໂຫລດ 50 μA ແລະ 100 μA ທີ່ $\pm 7.1 \text{ kV}$ ແລະ $\pm 6.9 \text{ kV}$ ຕາມລຳດັບ ຂອງແຮງດັນດ້ານຂາອອກຂອງເຄື່ອງ ກຳເນີດໄຟຟ້າແຮງສູງ, ເມື່ອປຽບທຽບຜົນທີ່ໄດ້ຮັບລະຫວ່າງຈາກການທົດສອບຈິງຂອງອຸປະກອນ ແລະ ຈາກ ການຈຳລອງທົດສອບໃນໂປຣແກຣມຄອມພິວເຕີ ແມ່ນບໍ່ຕ່າງກັນຫຼາຍທີ່ຍອມຮັບໄດ້.

ຄຳສຳຄັນ: ເຄື່ອງກຳເນີດໄຟຟ້າແຮງສູງ, ວົງຈອນ Cockcroft-Walton, ແຮງດັນສອງຂົ້ວ, ໄຟຟ້າແຮງສູງ ຫຼາຍຂັ້ນ.

Abstract

This research presents a new approach to design the high voltage power supply with multi-stages voltage and dual polarities. Each stages and polarity can application in many different purposes in laboratory. Operation principles and design considerations based on high-voltage technique design which these are discussed and analyze. Finally, high voltage DC power supplies had been implemented and test to verify the feasibility of the proposed scheme shown load 50 and 100 micro-amperes with $\pm 7.1 \text{ kV}$ and $\pm 6.9 \text{ kV}$ output voltages respectively. These results had been showed good agreement which compare with simulation.

Keywords: High Voltage Power Supply, Cockcroft-Walton circuit, Voltage dual polarities, High Voltage multi-stages.

1. Introduction

In high voltage technology direct voltages are mainly used for pure scientific research work and for testing equipment related to HVDC transmission systems. There is still a main application in tests on HVAC power cables of long length, as the large capacitance of those cables would take too large a current if tested with AC voltages. Although such DC tests on AC cables are more economical and convenient, the validity

of this test suffers from the experimentally obtained stress distribution within the insulating material, which may considerably be different from the normal working conditions where the cable is transmitting power at low-frequency alternating voltages. For the testing of polyethylene high voltage cables, in use now for some time, DC tests are no longer used, as such tests may not confirm the quality of the insulation (W. S. Z. E. Kuffel, J. Kuffel, 2000). High DC voltages are even more extensively used in applied physics (accelerators, electron microscopy, etc.), electromedical equipment (X-rays), industrial applications (precipitation and filtering of exhaust gases in thermal power stations and the cement industry; electrostatic painting and powder coating, etc.), or communications electronics (TV, broadcasting stations). Therefore, the requirements on voltage shape, voltage level, and current rating, short- or long-term stability for every HVDC generating system may differ strongly from each other. With the knowledge of the fundamental generating principles it will be possible, however, to select proper circuits for a special application (Sumruy Sangsaart, 2006).

In the order of DC high voltage generate, there are many factor to concentrate as main of them is cost of equipment, the traditional technique on create dc power supply was carried out transformer which that is high cost to creation. Moreover, this power supply is not facilities with application on the field cause high weight and difficult to setup (W. S. Z. E. Kuffel, J. Kuffel, 2000).

Nowadays, there are methodology to application for create the DC high voltage power supply. Concept of technique is converted AC to DC voltage. It is lower cost to creation and simply.

In this study, main emphasis has been focused on:

- ① The design simulation and development of the high voltage DC power supply.
- ② The high voltage DC power supply is constructed on hardware assemble and it can be used for multiple purposes.
- ③ Finally, based on Cockcroft-Walton (C-W) voltage multiplier circuits, the prototype is tested in the laboratory with the output range of 50 kV.

2. Methods and Materials

The method base on Cockcroft-Walton circuit, it is a voltage multiplier that converts AC or pulsing DC electrical power from a low voltage level to a higher DC voltage level. It is made up of a voltage multiplier ladder network of capacitors and diodes to generate high voltages. Unlike transformers, this method eliminates the requirement for the heavy core and the bulk of insulation/potting required. Using only capacitors and diodes, these voltage multipliers can step up relatively low voltages to extremely high values, while at the same time being far lighter and cheaper than transformers. The biggest advantage of such circuits is that the voltage across each stage of the cascade is equal to only twice the peak input voltage in a half wave rectifier. In a full wave rectifier it is three times the input voltage. It has the advantage of requiring relatively low cost components and being easy to insulate. One can also tap the output from any stage, like a multi-tapped transformer.

The Fig.1 illustrates CW circuit with multi-stage. Its operation as at the time when the AC input reaches its negative pole the leftmost diode is allowing current to flow from the ground into the first capacitor, filling it up. When the same AC signal reverses polarity, current flows through the second diode filling up the second capacitor with both the positive end from AC source and the first capacitor, charging the second

capacitor to twice the charge held in the first. With each change in polarity of the input, the capacitors add to the upstream charge and boost the voltage level of the capacitors downstream, towards the output on the right. The output voltage, assuming perfect conditions, is twice the peak input voltage multiplied by the number of stages in the multiplier (W. S. Z. E. Kuffel, J. Kuffel, 2000, Sumruy Sangsaart, 2006, Cockcroft, J.D. and Walton, E.T.S. 1932).

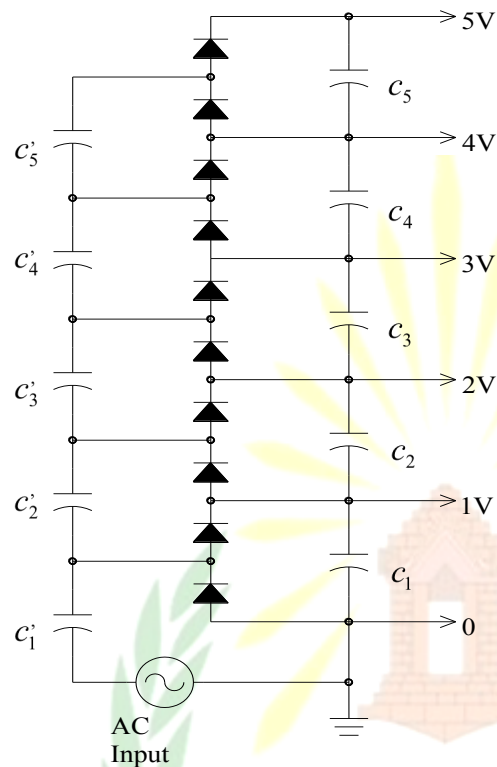

Figure. 1. Cockcroft-Walton 5 stages schematic

The ideal maximum output voltage on each stage is following equation:

$$V_{\max} = 2n_{(\text{stages})} \times V_{\text{input}} \quad (1)$$

In practice, the CW has a number of drawbacks. As the number of stages is increased, the voltages of the higher stages begin to "sag", primarily due to the electrical impedance of the capacitors in the lower stages. And, when supplying an output current, the voltage ripple rapidly increases as the number of stages is increased. For these reasons, CW multipliers with large number of stages are used only where relatively low output current is required. These effects can be partially compensated by increasing the capacitance in the lower stages, by increasing the frequency of the input power and by using an AC power source with a square or triangular shaped waveform. By driving the CW from a high frequency source, such as an inverter, or a combination of an inverter and HV transformer, the overall physical size and weight of the CW power supply can be substantially reduced (Cockcroft, J.D. and Walton, E.T.S. 1932. N. Mariun, D. Ismail, K. Anayet, N. Khan and M. Amran 2006)

Therefore, the output voltage under load is described by the equation below:

$$V_{drop} = \Delta V = \frac{I_{Load}}{fC} * \left(\frac{2}{3}n^3 + \frac{1}{2}n^2 - \frac{1}{6}n \right) \quad (2)$$

Where: I_{Load} : is current draw of the load .

f : frequency
 C : Stage capacitance
 n : The number of stages

Consequently, the output voltage in (1) can rewrite:

$$V_{out} = V_{max} - V_{drop} - 2\delta V \quad (3)$$

The ripple voltage, in the case where all stage capacitances (C_1 through C_{2*n}) be calculated from:

$$\delta V = \frac{I_{Load}}{2f} \left(\frac{1}{C_1} + \frac{2}{C_2} + \frac{3}{C_3} + \dots + \frac{n}{C_n} \right) \quad (4)$$

From equation (4), the number of stages increased. A common modification of the design is to increase the stage capacitances to a larger value at the first stage for term C' , but $C_1 = C_2 = C_3 = C_4 = C$, so in this case, the ripple is:

$$\delta V = \frac{I_{Load}}{fC} \times \frac{n(n+1)}{4} \quad (5)$$

For large values of $n \geq 5$, the $n^2/2$ and $n/6$ terms in the voltage drop equation (2) become small compared to the $2/3n^3$. Differentiating the drop equation with respect to the number of stages gives an equation for the optimum number of stages (for the equal valued capacitor design).

$$n_{optimum} = \sqrt{\frac{V_{input} \times f \times C}{I_{load}}} \quad (6)$$

Some case, for higher stages the output voltage is frequently higher than the expected value. This is not an intrinsic property of the CW generator, but rather an effect due to the high frequency and circuit itself, which act on the AC signal from the function generator with nontrivial distortions visible on the oscilloscope that have the effect of slightly boosting the average amplitude of the AC signal itself for high numbers of stages; these slight distortions are then themselves magnified up to 20 times as they go up the chain (Cockcroft, J.D. and Walton, E.T.S. 1932).

2.1 Waveform dependence

Cockcroft-Walton generator's efficiency to some extent depends on the input waveform. The output voltage is lowest for triangle waves, and highest for square waves, with sine waves in the middle; for small numbers of stages, these differences were small particularly between the sine and triangle waves – but could result in differences of up to 10V in output between the square and sine wave inputs for higher stages. The Cockcroft-Walton generator favors square waves over sine waves and sine waves over triangle waves because the AC signal spending more time at the highest voltages allows the capacitors to charge faster (N. Mariun, D. Ismail, K. Anayet, N. Khan and M. Amran 2006, C. K. Dwivedi and M. B. Daigavane 2011, Spencer DFR. Aryaeinejad and E.L. Reber 2001).

2.2 Frequency dependence

While the Cockcroft-Walton generator's output voltage is nominally frequency-independent, the fact that it works not at all at DC combined with the impedances of the capacitors implies strong frequency dependence. In fact, the output voltage of the CW generator was found to approach its maximum value logarithmically on a large range of frequencies for the lower stages.

3. Implemented

3.1 Simulation

The simulation was using the TINA[®] computer program to simulate the Cockcroft-Walton circuits. The conditions are as the following:

- The rating voltage and capacitance of capacitors in each stage are 35 kV and 0.18 μ F respectively.
- Twenty diodes of BY225 with an average forward current of 500mA and peak reverse voltage at 1.4kV are connected in series in each stage.
- The input of the voltage double circuit for the simulation has been set to 5kV_{p-p} and is connected as in simulation diagram shown in Fig. 1.

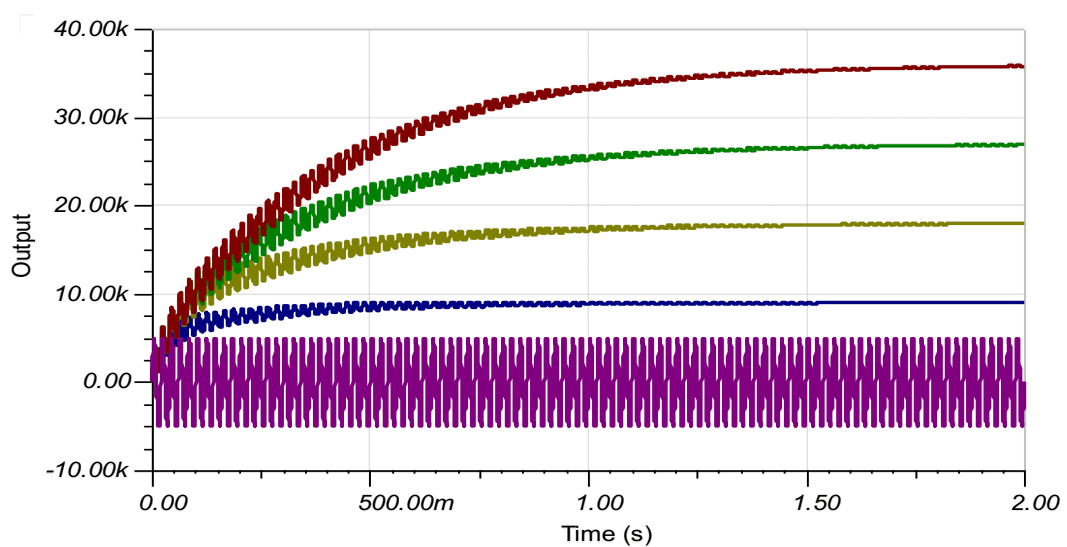

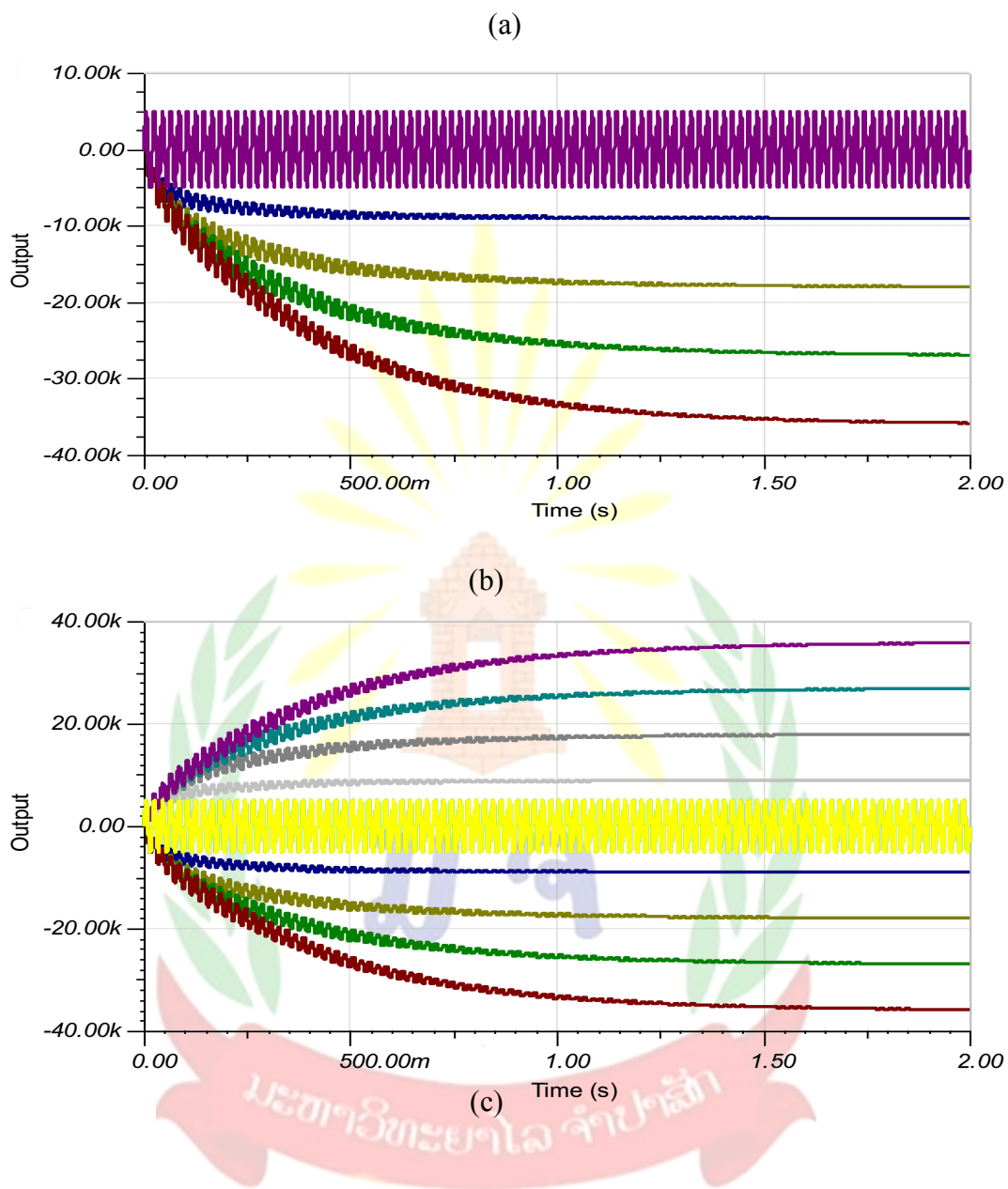

Figure. 2. Output of four stages from simulation on polarity of: (a) Positive, (b) Negative and (c) Two polarities

The simulation results show the output voltages are increased on the each stage, the voltage drop increased relationship with load current, the result as shown in Fig. 2.

3.2. The experiment.

The practically circuit is showed on Fig.3. Which divide to seven parts as: No.1. Power circuit (circuit breaker and magnetic contactor), No.2. Variable voltage regulator rated 0-220 Volts 50Hz 2.0 Amperes, No.3. Resistive limiting current, No.4. Isolating transformer ratio 1:1, 2 A, No.5. Neon transformer 0-220 Volts / 7.5KV capacities 1500VA, N.6. Five stages Cockcroft-Walton voltage pentadrupler circuits that is constructed based on hardware assembled and No.7. Resistive Voltage divider ratio 2000:1.

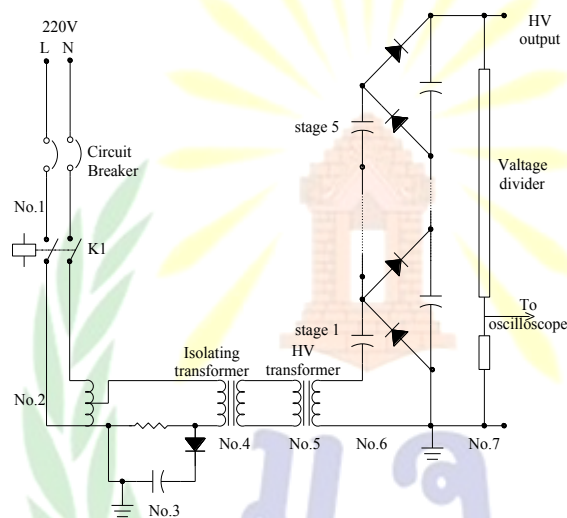

Figure. 3. The circuit diagram for experiment

4. Results and discussion.

The output voltage of DC power supply constructed on the each stage had been measured by oscilloscope, the experiment provide input voltages varies from 0-1,000_{RMS} volt AC. The results show advantage of device, for only 1.3 kV of input voltage can generate large output voltage on each stage. The increasing of voltage depends on number of stage like second stage to last stage of device. The output voltages on each stage are shows in the table 1 and the waveforms of output voltage are shows on Fig. 4 -6.

Table 1: The output voltage of power supply at 1.3kV peak to peak input voltage.

| No. Stage | Ripple Voltage (Volt) | Output Voltage (Volt) |
|-----------|-----------------------|-----------------------|
| | | |

| | | |
|---|------|--------|
| 1 | 20.5 | 1,830 |
| 2 | 22.7 | 3,800 |
| 3 | 36.2 | 7,710 |
| 4 | 54.3 | 10,050 |

The measurement had done by special equipment which base on technique of high voltage. All output for measure had been divided by voltage divider (Ratio 1050:1) and isolate signal from other resource.

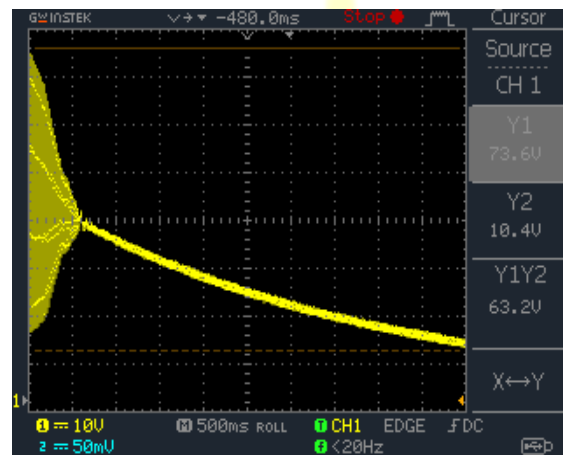

Figure. 4. The Output voltage of DC power supply which displays on monitor of digital oscilloscope.

Due to load of DC power supply as voltage divider, the output voltage will never reach the value $2nV_{\max}$ as shown in Fig. 4. There will also be a ripple on the voltage, and therefore we have to deal with two quantities: the voltage drop (ΔV_{out}) and the peak-to-peak ripple $2\delta V$. The Fig. 5. shows the shape of the output voltage and the definitions of ΔV_{out} and $2\delta V$. Increasing of ripple voltage depend on number of stage as shows in table 1.

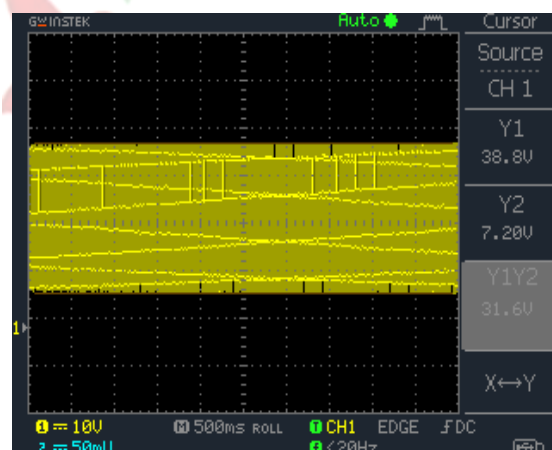

Figure. 5. The ripple voltage of output

However, the feasibility of loads are 50 and 100 micro-amperes with ± 7.1 kV and ± 6.9 kV respectively.

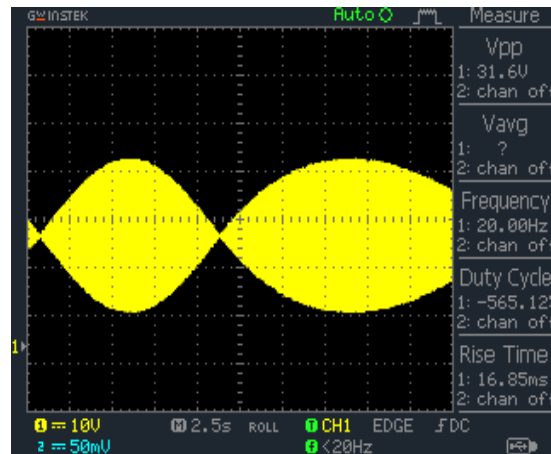

Figure. 6. The characteristic of ripple voltage.

The distortion of ripple voltage as Fig. 6 it is resulting of charge and discharge of capacitor. The characteristic of them like as waveform of the system.

5. Conclusions

The research had been design and experimental based the simulation on the computer program which has been used as a guideline for developing the hardware. The Cockcroft-Walton methodology application for create the hardware. The constructed hardware has been successfully implemented and tested at Champasack University, Faculty of Engineering. The simulation and experimental results have been observed to be in good agreement. This Cockcroft-Walton voltage pentadrupler circuits is also suitable for larger output voltages and can be connected in modular type. The large ripple voltage still appearance, which due to characteristics of capacitor on their state space of charge and discharge. The disadvantage of two polarities of DC high voltage power supply measurement are suffer difficult in practice which can done by separate measurement.

Acknowledgement

The authors would like to thank for ADB Grant 0166-LAO (SF): Strengthening Higher Education Project (SHEP) to support for this research.

References

- W. S. Z. E. Kuffel, J. Kuffel, "High Voltage Engineering", Second edition, Oxford Auckland Boston Johannesburg Melbourne New Delhi, pp. 460-464, 2000.
- Sumruy Sangsaart "High Voltage Engineering", Department of Electrical Engineering. Faculty of Engineering Chulalongkorn University, pp. 20 -23, 2006.
- Cockcroft, J.D. and Walton, E.T.S. (1932). Proc. R. Soc. London A137:229.

- N. Mariun, D. Ismail, K. Anayet, N. Khan and M. Amran, "Simulation, Design and Construction of High Voltage DC Power Supply at 15 kV Output Using Voltage Multiplier Circuits", American Journal of Applied Sciences 3 (12) pp. 2178-2183, 2006.
- C. K. Dwivedi and M. B. Daigavane, "Multi-purpose low cost DC high voltage generator (60 kV output), using Cockcroft-Walton voltage multiplier Circuit", International Journal of Science and Technology Education Research Vol. 2(7), pp. 109 - 119, July 2011.
- Spencer DFR. Aryaeinejad and E.L. Reber 2001. "Using the Cockcroft-Walton Voltage Multiplier Design in Handheld Devices". Idaho National Engineering and Environmental Laboratory, P.O. Box 1625, Idaho Falls, ID 83415.

